

This drawing and the information contained herein are the confidential and proprietary property of Global Supply LLC

A=	BOARD THK	A WIDTH
.04	0.031	0.04
.075	0.063	0.075
.105	0.094	0.105
.142	0.125	0.142
.165	0.156	0.165

MATERIAL = M
A - ALUMINUM ALLOY 5052-H32
S-STAINLESS STEEL
T-ALUMINUM ALLOY 6061-T6

FINISH = F
C - CHEMICAL FILM (GOLD)
P - PASSIVATE
B - BLACK ANODIZE
E - CHEM FILM (GOLD)SED
1 - RED ANODIZE
2 - BLUE ANODIZE
3 - GREEN ANODIZE
4 - YELLOW ANODIZE
6 - ORANGE ANODIZE
7 - PURPLE ANODIZE
8 - GRAY ANODIZE
9 - BROWN ANODIZE
0 - CLEAR ANODIZE

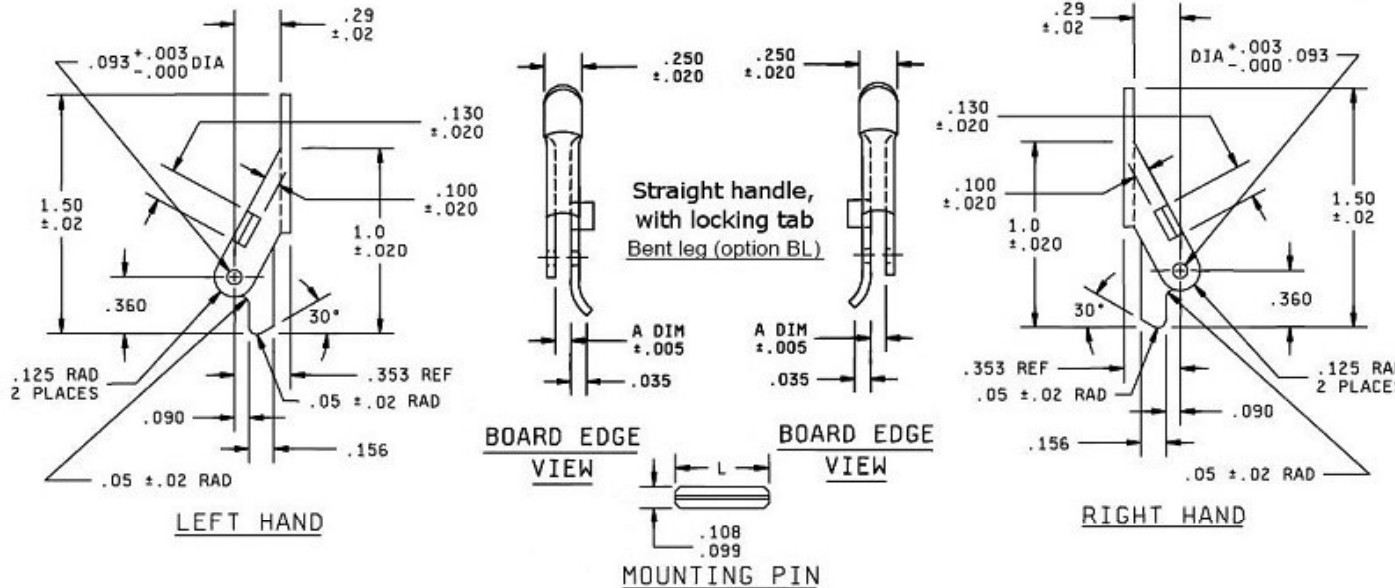

NOTES:

1. INTERPRET DRAWING PER ASME Y14.5M-1994
2. ROHS AND REACH COMPLIANT

DRAWING SCALE:		MATERIAL:	DESCRIPTION:
STANDARD		SEE MATERIAL CHART	METAL CARD EJECTOR, STRAIGHT HANDLE, BENT LEG, LOCKING TAB
TOLERANCES: <i>Unless specified otherwise, all dimensions are in inches</i>	x.xxx +/- 0.005 x.xx +/- 0.010 x.x +/- 0.010	FINISH:	PART NUMBER:
		SEE FINISH CHART	ME-SH-(A)-(L or R)(M)(F)BLT
DRAWN BY:	L. Clary	FCSM No. 67012	 Global Supply LLC WORLDWIDE SUPPLIER OF ELECTRONIC HARDWARE, FASTENERS & COMPONENTS 500 Division Street, Campbell, CA 95008-6906 Tel: 408 960 0370 Fax: 408 960 0375 Web: www.globalsupply.com
REV:	APPROVAL		
Initial Release	LJA	Mar 26, 2019	
		ECCN	
		EAR99 = NLR (No License Required)	